

# Safety Guidelines for *Solid-Fuel Burning Appliances*

---



---

**GRINNELL MUTUAL**  
REINSURANCE            SINCE 1909

*A Policy of Working Together for your Safety*

## **Legal Disclaimer**

**The information contained herein is not intended to be used as a guide for installation or operation of any solid or liquid fuel heating device. Use of this information is at your own risk. Please refer to your local or state building codes for installation and operational compliance.**

# Table of Contents

Solid-Fuel Burning Appliance Frequently Asked Questions .....	1
Woodburning Stoves.....	3
Circulating Room Heaters .....	3
Radiant Room Heaters.....	3
Room Heater/Fireplace Stove Combination aka. Franklin Stove.....	3
Stove Construction:	
Sheet Metal.....	4
Welded Steel.....	4
Cast Iron .....	4
What do I need to know about installing my woodstove?.....	5
Clearances.....	5
Table – Reducing Clearance from Woodburning Appliance & Connector Pipe.....	6
Clearance from Floors .....	7
Connecting Pipe .....	7
Installing Connecting Pipe to Chimney.....	8
Multiple Venting .....	9
Operation .....	10
Combustion.....	10
Control of Creosote.....	11
Chimney Fires.....	12
If a Fire Occurs .....	12
Chimney Inspection and Cleaning.....	13
Disposal of Ashes .....	13
Fire Extinguishers and Smoke Detectors .....	13
Special Safety Points.....	14
Chimneys for Woodstoves.....	14
Flue .....	15
Masonry Chimneys.....	16
Factory-Built Chimney Units .....	18
Smoky Fires – Causes.....	19
What Type of Wood Should I Use? .....	19
Firing Instructions for Wood Stoves.....	20
Guidelines for <b>Interior</b>	
Corn Burning Furnaces, Boilers and Stoves .....	21
Guidelines for <b>Exterior</b>	
Woodburning and Cornburning Furnaces and Boilers.....	24
Solid Fuel Burning Appliance Checklist .....	27

# Solid-Fuel Burning Appliance FAQ's

***NFPA 211 (Standard for Chimneys, Fireplaces, Vents and Solid Fuel-Burning Appliances) is the standard that applies to solid fuel-burning appliances.***

**Q. In what kind of space can a solid fuel-burning appliance be installed?**

- Any level of the home as long as it is designed for that use and is accessible.
- Installation in alcove or space less than 512 cubic feet is prohibited unless the appliance is designed and listed for such use.

**Q. Can a solid fuel-burning appliance be installed in a garage?**

No, solid fuel-burning appliances shall not be installed in any garage or any location where gasoline or other flammable vapors are present.

**Q. What is a heat reclaimer and can I have one installed on my appliance?**

- A heat reclaimer is a device attached to your stove pipe that is designed to extract heat from flue gases.
- As the authority having jurisdiction, Grinnell Mutual Reinsurance Company prohibits the use of a heat reclaimer. It can cause excessive creosote build up in the stove pipe and chimney due to the reduction in the temperature in the flue. This creates an increased risk of a chimney fire.

**Q. How should I store my ashes?**

Your ashes shall be stored in a metal container with a lid. This container must be sitting on a non-combustible surface. This container shall be at least 36 inches from combustibles and is best stored outside whenever possible.

**Q. Do I need a fire extinguisher and if so what kind?**

Yes, you need at least one 10 pound ABC dry chemical fire extinguisher readily available.

**Q. Do I need smoke and carbon monoxide detectors?**

Yes, smoke detectors shall be installed on each level of the home and carbon monoxide detectors shall be installed in the hallway outside the bedrooms in each separate sleeping area of the home. Check with your fire marshal for specific codes in your area.

**Q. Can I use artificial logs in a wood burning stove?**

No, the use of artificial logs in a wood burning stove can cause an explosion.

**Q. Can a stove be connected to an existing flue that serves another heating appliance?**

National Fire Protection Association (NFPA) recommended standard prohibits connecting a stove to a chimney flue serving another appliance burning dissimilar fuels unless it is listed for such a connection.

**Q. Can a solid-fuel burning appliance be installed in a mobile home?**

Only if the stove is listed for installation in a mobile home and is installed according to the manufacturer's specifications.

# Woodburning Stoves

## Circulating Room Heaters

- Double-walled with an inner combustion chamber and are usually constructed of cast iron or firebrick-lined welded steel.
- Outer shell of lightweight sheet metal promotes the flow of air over the inner shell.
- Room is primarily heated by warm air circulated by the stove.
- Draft control and heat output are obtained with thermostatically controlled damper.
- Burning efficiencies of 60 to 70 percent are possible with well-built units.
- The outer shell stays relatively cool during operation which is a major advantage of the circulating unit.

## Radiant Room Heaters

- Single walled units that are constructed of sheet metal, cast iron or welded steel.
- Firebrick lining is an option that improves the stove's efficiency and extends the life of the stove.
- Heat is transferred to the room in two ways, by radiant energy and indirectly by convection currents set up by air flow over the surface of the stove unit.
- Draft & heat control are often obtained by manually operated dampers, but also may be automatic.
- Combustion efficiency for these units can be as high as circulating units.
- Poor management of the manual draft controls can cause lower efficiencies.

## Room Heater/Fireplace Stove Combination aka "Franklin Stove"

- Radiant type heater that has a door which can be opened to provide a view of the fire without adversely affecting the stove operation.

- Traditionally efficiencies are in the 50 to 60 percent range, but this is dependent on the amount of time the unit is operated in “fireplace” mode.
- The traditional home fireplace efficiencies are in the 10 to 20 percent range.

### **Stove Construction – Sheet Metal**

- UL Listed
- Constructed with sheet metal, welded steel or cast iron fire box.
- The stove may be lined with firebrick.
- Sheet metal stoves are only for occasional use because they are lightweight, warm up rapidly and deteriorate with excessive use.
- Limiting the size of fires and/or lining the fire area with heavier material or firebrick can increase the life of the stove.
- Frequent inspections should be performed to identify weak spots in the sheet metal.

### **Stove Construction – Welded Steel**

- UL Listed
- Constructed of at least ¼ inch steel plate.
- Warm up slower than sheet metal stoves, but have a longer life due to thicker wall sections.
- Welded steel stoves are suitable for continuous use.
- Higher quality models contain firebrick in the combustion area.

### **Stove Construction – Cast Iron**

- UL Listed
- Considered “top of the line” of woodburning stoves.
- Stove warms up slowly, retains heat, does not warp and lasts for several years.
- Basically same efficiency as other well-built stoves.
- Cast iron is brittle and can develop cracks if handled roughly.
- Units should be carefully inspected for cracks prior to use.

## What do I need to know about installing my woodstove?

- You must strictly follow all Manufacturer's installation instructions.
- The place you install it is usually determined by the location of an existing chimney flue or the potential location of the chimney.
- Adequate clearances must be maintained from combustible surfaces.
- Access to the connector pipe and chimney flue is a must and needs to be considered to allow for necessary periodic cleaning.
- Wood stoves that are not designed with positive circulation systems should be located near the center of the area to be heated.

## Clearances

The National Fire Protection Agency (NFPA) recommends specific clearances between woodstoves and protected and unprotected combustible walls and ceilings.

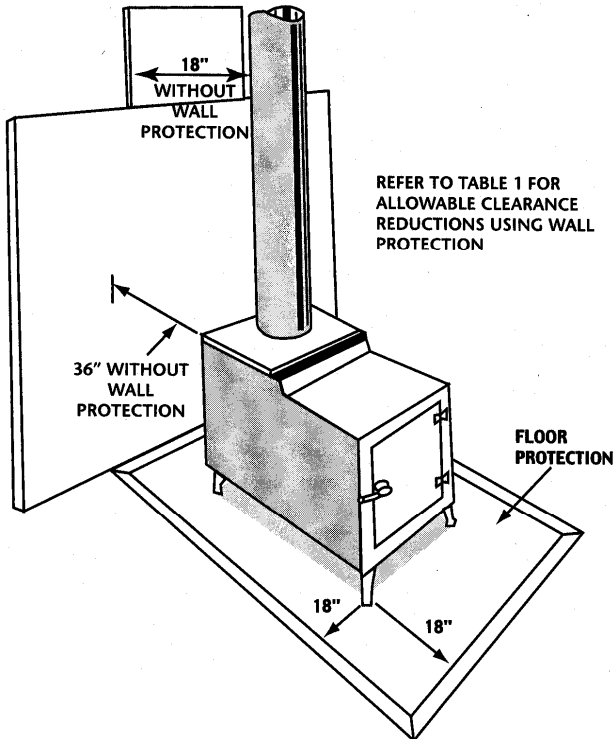



## Table 1

<b>Reducing Clearance from the Wood burning Appliance &amp; Connector Pipe</b>				
It is possible to reduce manufacturer's or NFPA 211 recommended clearances from the wood burning appliance and connector to combustible surfaces. When the required clearance with no protection is 18 inches or 36 inches respectively the allowable clearance reduction is shown below.				
<b>Combustible Surface Covering</b>	<b>As Wall Protector</b>		<b>As Ceiling Protector</b>	
	<i>Appliance</i>	<i>Connector</i>	<i>Appliance</i>	<i>Connector</i>
3 ½ inch thick masonry wall without ventilated air space	33% – 24"	33% – 12"		
1/2 inch thick non-combustible insulation board over 1 inch glass fiber or mineral wool batts without ventilated air space	50% – 18"	50% – 9"	33% – 24"	33% – 12"
24 gage sheet metal over 1 inch glass fiber or mineral wool batts reinforced with wire or equivalent, on rear face with ventilated air space	66% – 12"	66% – 6"	50% – 18"	50% – 9"
3 ½ inch thick masonry wall with 1 inch ventilated air space	66% – 12"	66% – 6"		
24 gage sheet metal with 1 inch ventilated air space	66% – 12"	66% – 6"	50% – 18%	50% – 9%
1/2 inch thick non-combustible insulation board with 1 inch ventilated air space	66% – 12"	66% – 6%	50% – 18"	50% – 9"
1 inch glass fiber or mineral wool batts sandwiched between two sheets of 24 gage sheet metal with 1 inch ventilated air space	66% – 12"	66% – 6"	50% – 18"	50% – 9"

**NOTE: After reduction, appliance clearance shall not be less than 12 inches to combustible walls and not less than 18 inches to combustible ceilings  
Connector clearance shall not be less than 6 inches to combustible walls and not less than 9 inches to combustible ceilings.  
Non-combustible spacers must be used. Refer to NFPA 211 for further details.**

## Clearances from Floors

- All floors under stoves must be protected from heat and hot coals that may fall out unless the floor is constructed of solid concrete.
- This protection should extend under the stove and outward for a distance of 18 inches on all sides.
- Manufacturers of listed solid fuel burning appliances usually specify the type of material required for floor protection.
- If the manufacturer's specifications are unknown, the type of floor protection required is dependent on the length of the appliance's legs.
- Solid fuel burning appliances with legs less than 2 inches in height must be installed on a non-combustible floor.
- Solid fuel burning appliances with legs 2 to 6 inches in length must be installed over floor protection consisting of 4 inch hollow masonry laid to provide air circulation through the layer and covered with 24 gauge sheet metal.
- Solid fuel burning appliances with legs greater than 6 inches in length must be installed over floor protection consisting of closely spaced masonry which provides a thickness of at least 2 inches. The masonry must also be covered by 24 gauge sheet metal.
- Another alternative is the use of a floor protector listed by a recognized testing laboratory and is installed in accordance with the listing requirements.
- Legs installed by the manufacturer should not be shortened or removed.
- No item shall be placed where it will interfere with the circulation of air under the appliance.

## Connecting Pipe

- Stoves are connected to chimney inlets with uncovered sheet metal pipe generally known as stove pipe or smoke pipe.
- The pipe is usually 6 to 8 inches in diameter and should be constructed of 24 gauge or heavier metal (lower the gauge number the heavier the metal)
- Pipe size should match the outlet size of the stove.
- Maximum efficiency is obtained when pipes are as short and as straight as possible.

- If the pipe runs horizontally to the chimney, there should be a minimum slope toward the stove of 1/4 inch per foot.
- Joints in the pipe should be assembled to funnel any liquid creosote accumulating in the pipe back to the stove where it will burn.
- Joints should fit tightly to eliminate entry of room air directly into the chimney system.
- Furnace cement may be used to insure tightness.
- Rivets or screws can be used at pipe joints for added strength.

## Installing Connecting Pipe To Chimney

- A minimum of 12 inches of solid masonry is required around a 5/8 inch fire clay thimble if the pipe passes through a combustible wall.

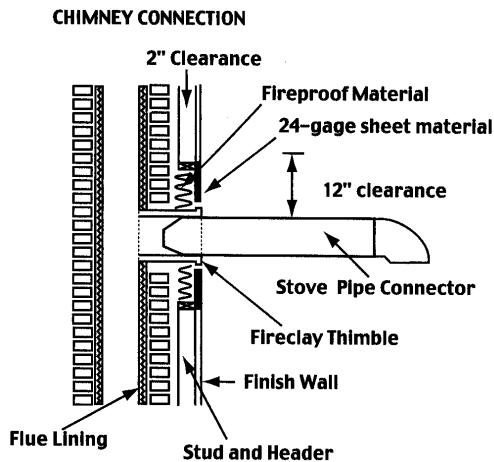

- It is also acceptable to use a UL listed prefabricated wall pass through.
- Under no circumstances should a connecting pipe extend through an area of the house that is unoccupied.
- When using a factory built chimney, the wall pass through or ceiling support is manufactured and listed as a part of the venting system.
- Installation of a factory built chimney must conform to the manufacturer's specifications.

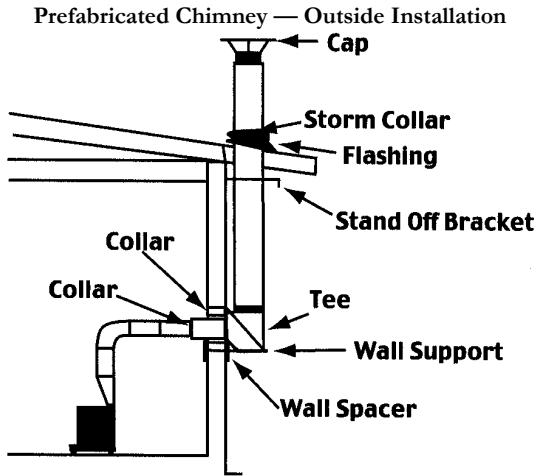

Prefabricated Chimney — Interior (Preferred) Installation

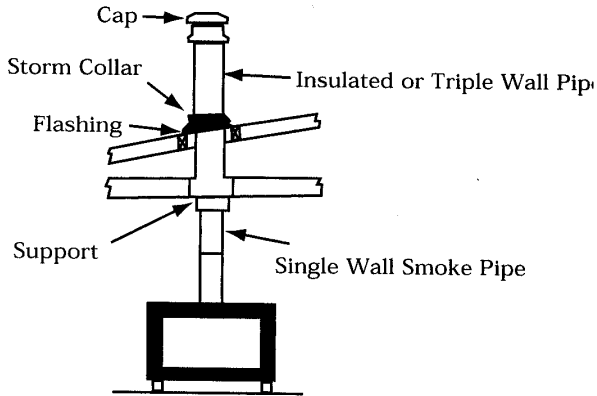

## Multiple Venting

- Solid fuel burning appliances should not be connected to a chimney flue serving another appliance such as gas or oil fired furnaces and water heaters unless that unit is listed and approved for such a connection.
- ***Venting two or more heaters into a single flue can increase the chance of a fire and allow dangerous gases (such as carbon monoxide) to enter your home.***

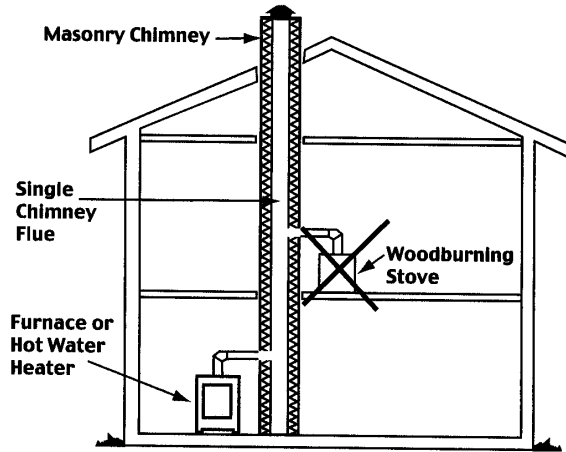

## Operation



- Once you have selected a proper solid fuel burning appliance and it has been installed according to manufacturer's specifications it is extremely important to ensure that it is operated properly.
- Many of the problems that arise with a correctly installed solid fuel burning appliance are a direct result of incomplete combustion.

## Combustion

- Combustion consists of a complex chemical reaction between the fuel (wood) and oxygen.
- The combustion of wood in a stove results in heat and water vapors, carbon dioxide, and other products of combustion (gases and ash).
- To assure satisfactory combustion and safe operation, several conditions must be met:
  - A continuous supply of oxygen for the fire and the occupants of the room or area.
  - A proper amount of fuel (wood) – enough to maintain a flue temperature that prevents the accumulation of creosote residues without causing overheating.
  - Proper burning to avoid wasted fuel and toxic products of combustion, such as carbon dioxide.
  - Removal of unwanted products of combustion (gaseous) products should be continuously removed while the stove is in

operation, and solid products (ashes) should be disposed of safely.

- Complete combustion can be assured by supplying air and maintaining a sufficient heat level.
- Incomplete combustion is a result of insufficient air supply, misapplied air or insufficient heat.
- New stoves with cast-iron parts should be “seasoned” to prevent cracking. This is accomplished by building only small fires for the first two or three uses.
- The entire system must be properly maintained to operate safely and efficiently.
- The chimney connectors, joints, and flues must be kept clean and functioning properly.

<b>Stages of Combustion</b>	
<p><b>1st Stage</b></p> 	<p>The wood is heated to evaporate and drive off moisture.</p> <p>This heat <u>does not</u> warm the stove or room.</p>
<p><b>2nd Stage</b></p> <p style="text-align: right;">500° F to 1100° F</p> 	<p>The wood starts to break down chemically at 500° F and <u>volatile matter is vaporized.</u></p> <p>These vapors contain between 50–60% of the heat value of the wood.</p> <p>At 1100° F these vapors burn. This high temperature must be maintained for <u>maximum efficiency of combustion.</u></p>
<p><b>3rd Stage</b></p> <p style="text-align: right;">Over 1100° F</p> 	<p>Following the release of volatile gases, the remaining material is <u>charcoal</u>, which burns at temperatures exceeding 1100° F.</p>

## Control of Creosote

- Creosote is a substance present in the smoke of a slow burning fire and usually collects in a cool chimney flue.
- The main causes of creosote build up are:
  - Wet or unseasoned wood.

- Incomplete combustion.
- Cool surfaces with the system.
- **The best method of controlling creosote build up is by maintaining a brisk burning fire with dry, well seasoned wood and by maintaining a flue temperature exceeding 250° F.**
- Some newer, more efficient stoves deliver more heat to the room than an open stove or fireplace, thus reducing the amount of heat escaping up the chimney and lowering the flue temperature. It is imperative to prevent creosote build up in these types of stoves and fireplaces. Additional inspections and clean-outs may be needed.

## **Chimney Fires**

- With the increased accumulation of creosote in the chimney flue comes the increased potential for a chimney fire.
- The combustion of these creosote deposits is most likely to occur during a very hot fire in your stove.
- The burning of creosote deposits will create a very intense fire, a roaring noise, and flames and sparks from the top of the chimney.
- A chimney (metal or masonry) can be weakened or deformed by a chimney fire.
- The complete chimney should be inspected after a fire, and any repair should be made and/or parts replaced before re-starting the stove.

## **If A Fire Occurs**

- **CALL YOUR LOCAL FIRE DEPARTMENT (i.e. 911) IMMEDIATELY!!!**
- **CLOSE ALL OPENINGS AND DRAFT CONTROLS ON THE STOVE**
- **If the fire is burning vigorously, spray a multipurpose dry chemical extinguisher onto the fire in the stove if it can be done safely.**
- **Avoid introducing water into the chimney if possible as the water could damage the heated flue liner.**

## **Chimney Inspections and Cleaning**

- Stove pipes and chimney flues should be inspected each year before you use your stove.
- Inspect for cracked flue liners, broken or missing chimney bricks, heavy creosote deposits, bird nests and other foreign materials.
- Thoroughly clean the flue and connecting pipe as necessary.
- The stove pipe and chimney should be inspected frequently during the heating season for creosote build up.
- If you use an air tight stove, check the connecting pipe and flue at least once a month.
- Flue cleaning requirements are dependent on how often the stove is used and how it is operated.
- A stiff wire chimney cleaning brush should be used for excessive build up.
- A professional chimney sweep is recommended for cleaning of the chimney.
- If you plan to use an existing chimney, always have your chimney professionally cleaned before your wood burning appliance is installed.

## **Disposal of Ashes**

- Ashes need to be stored in a non-combustible metal container with a tight fitting lid.
- The closed container needs to be placed on a non-combustible floor or on the ground, at least 3 feet away from all combustible materials until their final disposal.
- **KEEP ASHES AWAY FROM SMALL CHILDREN – SWALLOWING ASHES MAY CAUSE ILLNESS!**

## **Fire Extinguishers and Smoke Detectors**

- A multi-purpose ABC dry chemical fire extinguisher should be installed for each stove, in addition to the extinguishers already in the home.
- The fire extinguisher should be located near each stove and should be easily accessible.
- Install smoke detectors to offer your family additional protection in case of fire and in many jurisdictions they are required by law.



## Special Safety Points

- Locate the heater out of high traffic areas due to the high temperatures created when the stove is operating.
- **KEEP ALL COMBUSTIBLE MATERIALS (i.e. walls, ceiling, furniture, rugs, draperies, fuel, clothing) AWAY FROM HEATERS TO AVOID THE POSSIBILITY OF IGNITION!**
- **KEEP CHILDREN AWAY FROM THE STOVE TO AVOID BURNS OR CLOTHING IGNITION!**
- **ALERT CHILDREN TO THE DANGER OF TOUCHING OR GETTING NEAR THE STOVE DUE TO THE HIGH SURFACE TEMPERATURE!**
- A qualified person should install and inspect the stove before its use and inspect and service it on at least an annual basis.

## Chimneys for Woodstoves

- All wood burning stoves need a well designed and constructed chimney that is tight to maximize efficiency and to minimize the danger of unwanted fire.
- Most homeowners who add a wood burning stove will also have to add a chimney.
- The chimney serves two major functions in stove operation:
  - It provides a draft, a vacuum which draws oxygen needed for combustion into the stove.
  - It discharges the products of combustion outside of the living area.
- Some of the heat from the stove and occasional sparks are also discharged through the chimney. For this reason, chimneys must be carefully constructed and well maintained.
- Draft is caused primarily by the natural rising of warm air (smoke) up the chimney.
- Generally speaking the taller the chimney the greater the draft.
- A warm chimney will provide a greater draft than a cool chimney because a warm chimney does not cool the rising smoke. That is why stoves generally perform better after they have run long enough to warm the chimney.
- Chimneys which are located within the house generally produce better draft than those located completely outside the house.

- Outside air currents can affect draft if they swirl around obstructions and blow down the chimney rather than across the opening.
- Eddy currents of air that affect draft are most often caused by wind blowing across nearby parts of the building roof. For this reason, acceptable clearances have been established to lessen the problem.
- A chimney must extend at least three feet above a roof and at least two feet above a roof ridge or any raised part of a roof within 10 feet.

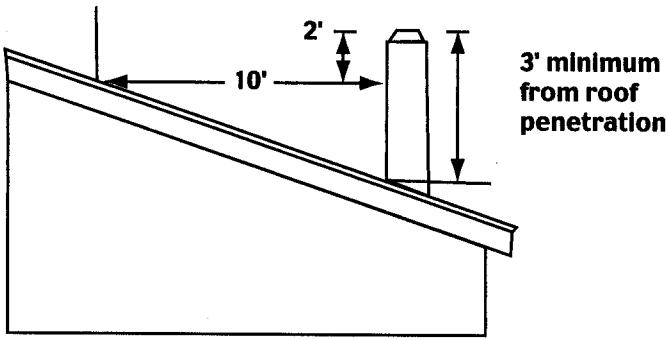

- Sometimes maintaining enough vertical clearance to prevent eddy currents from affecting chimney draft is impossible. This may be due to unusual heights of nearby trees.
- A hood or chimney cap can sometimes be used to prevent eddy currents from interfering with draft.
- Caps and hoods also minimize rain entry into the chimney during periods of non-use.

## Flue

- The opening in the chimney through which smoke passes is called the flue.
- In order to provide adequate room for smoke passage and draft development, flues must be carefully sized in relation to stove capacity and chimney height.
- The general rule is the flue size should be equal to and no more than 3 times larger than the cross sectional area of the stove pipe which connects the stove to the chimney.

- This means a stove with a 6 inch diameter would require at least a 6 inch but no more than a 10 inch flue.
- Smoke moves up the flue in a swirling pattern.
- Round flues are more efficient than square or rectangular ones because they offer little obstruction to the natural flow of smoke up the flue.
- To achieve the best performance, the inner surface of the flue should be as smooth as possible.
- NFPA standards prohibit connecting a stove to a chimney flue serving another appliance burning dissimilar fuels unless listed for such a connection.
- NFPA recommends that each stove be connected to a separate flue. This reduces interference between units and increases the efficiency of each appliance.

## **Masonry Chimneys**

- Many chimneys in new and existing homes are constructed of noncombustible masonry material such as brick, chimney block or stone.
- Masonry chimneys must be constructed on a concrete footing to support the chimney without settling.
- Chimney footings must extend below normal frost depth and rest on undisturbed or well compacted soil.
- They should be lined with vitrified fire clay tile (flue tile), or another listed lining material as outlined in NFPA 211. This type of tile is designed to withstand rapid fluctuations in temperature without cracking and has a smooth surface that is easily cleaned.
- Flue tile should be at least 5/8 inch thick.
- The most commonly used sizes in residential construction are 8" x 8", 8" x 13", 13" x 13" (outside dimensions).
- Flue tiles are cemented together with refractory mortar, which is struck smooth on the inside.
- There should be a minimum ½ inch and maximum 4 inch space between the outside of the flue tile and the surrounding masonry to reduce heat loss through the chimney and allow for thermal expansion.
- Relining of masonry chimneys is acceptable as long as listed products are installed according to their listing.

- Brick walls for chimneys must be at least 4 inches thick.
- If rubble stone is used for the wall, a 12 inch minimum thickness is needed.
- Chimney block may also be used and must be 4 inch solid masonry or 6 inch hollow masonry with the cells fully filled with mortar. In both cases, the block must be waterproofed.
- Masonry units should be laid with cement mortar.
- It is acceptable for a chimney to contain more than one flue, but they must be separated by 4 inch thick solid masonry.
- Interior masonry chimneys must be separated from combustible material/walls by at least 2 inches on all sides. Framing and other combustible materials in walls, floors, ceilings and roofs must stop at least 2 inches from the chimney. The 2 inch space must be filled with sheet metal or other non-combustible material to provide a fire stop.
- Connection of the smoke pipe to a masonry chimney is made through the use of thick round fire clay or 24 gage galvanized steels units called thimbles.
- Thimbles are installed horizontally into the chimney wall.
- Thimbles must not extend into the chimney beyond the inner surface of the flue liner (see below).

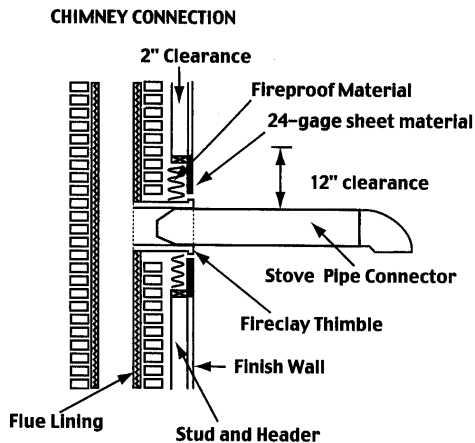

- Soot and creosote will accumulate on the inner surface of flues.
- A tight fitting clean-out door should be installed at the base of the chimney to assist in cleaning.

## Factory-Built Chimney Units

- Due to the difficulty in adding a masonry chimney unit to an existing home and the impracticality in adding one to some new home designs, a listed factory-built chimney unit may be the best choice for wood stoves or fire places in these homes.
- Factory-built chimneys are easier to construct than masonry units and although the materials may cost more the total unit cost will be nearly the same due to the time saved constructing it.
- Factory-built units are relatively light weight and do not need a heavy foundation.
- If a factory-built unit is installed through a closet or unused room corner the chimney must be enclosed and minimum clearance requirements must be maintained.
- Factory-built chimneys used for wood stoves must bear the Underwriters Laboratories (UL) listed label and be designed for ALL FUEL chimney units.
- **UL LISTED VENTS COMMONLY USED FOR OIL OR GAS FIRED HEATERS ARE NOT SATISFACTORY FOR USE WITH WOOD STOVES.**
- The two UL listings which must be noted are UL 103 and UL 103 HT. For stoves that operate with the loading door closed a UL 103 HT chimney is required.
- Freestanding fireplaces and heaters that operate with the door open can be connected to chimneys with the UL 103 listing.
- The UL 103 HT listing requires more rigorous testing.
- The two general types of factory-built chimneys available are the insulated unit and the triple walled unit.
- Insulated units are constructed of inner and outer layers of metal (usually stainless steel) with the space between filled with one or more inches of non-combustible insulation.
- Triple walled units have three layers of metal and are designed so that air circulates between the layers to remove excess heat.
- Both types are acceptable as long as they are UL listed, suited for the appliance it is being used with and is properly installed according to the manufacturers specs.
- Factory-built chimneys are available in several sizes, and a variety of accessories are available to accommodate different types of installation.

- Generally, there is a required 2 inch clearance between the unit and combustible materials.
- **YOU MUST INSTALL IT ACCORDING TO THE MANUFACTURER'S INSTALLATION REQUIREMENTS.**

## Smoky Fires – Causes

- **CHIMNEY OBSTRUCTIONS** can be caused by bird nests, fallen bricks and a variety of other objects.
- Any object that restricts the smooth flow of exhaust gases can cause a smoky fire. A good cleaning is the solution to this problem.
- **LACK OF COMBUSTION AIR** can cause a smoky fire. This is occasionally seen in new, tightly constructed homes where there are not enough natural openings to supply air for the stove. This restricts the chimney draft and causes smoking to occur.
- Opening a window slightly or providing some other source of outside air will usually eliminate this problem.
- Unusual wind direction resulting in abnormal eddy currents can also cause smoking. If this is a persistent problem, extending the chimney height or adding a cap may help.
- Burning green or wet wood can also cause smoking as well as burning too cool of a fire. These can prevent the chimney from warming up and developing full draft.
- If wet or green wood must be burned, wait until the fire is going well and then mix it with dry wood to keep the chimney temperature up.

## What Type of Wood Should I Use?

- Burn dry and well-seasoned hardwood.
- Season wood at least six months, preferably a year to eighteen months before using.
- If you ignore this advice you will most likely have a dirty chimney and inadequate heat from your stove.
- Green wood is heavier and looks different than seasoned wood, which will often show cracks radiating outward from the center towards the bark, green wood will not.

## Firing Instructions for Wood Stoves

- Cover the bottom of the stove with approximately 1 inch of sand.
- This protects the floor and the bottom plate from the extremes of heat.
- To start a fire, place a small pile of paper and kindling at the front of the stove.
- Place heavier wood on the kindling.
- A wad of paper placed in front of the kindling works well.
- The draft will draw flame from the paper through the kindling, igniting it.
- Do not do anything that will cause sudden sharp changes in the temperature of the cast iron.
- Do not throw cold water on a hot stove.
- Do not use the stove as an incinerator for trash.
- Do not store wood near or under the stove.
- **NEVER USE GASOLINE, KEROSENE, CHARCOAL STARTER FLUID OR A SIMILAR ACCELERANT TO START A FIRE!**

# **Guidelines for Interior Corn Burning Furnaces, Boilers and Stoves**

All interior heating systems located within buildings that GMRC insures or reinsures, must be tested, listed and approved by a nationally recognized organization following established recognized safety standards (i.e. UL 391 is the Solid-Fuel and Combination-Fuel Central and Supplemental Furnaces Standard and UL 1482 is the Solid-Fuel Type Room Heaters Standard). Nationally recognized organizations include Underwriters Laboratories (UL), Warnock Hersey, OMNI-Test Labs, etc.

The unit must be specifically designed for interior installations. Installing a heating system that was designed, tested, listed and/or approved for exterior installation inside of a building or enclosure is NOT acceptable.

The heating system must be installed in accordance with the manufacturer's recommendations with regards to clearances to combustible materials. This would include distances to combustibles from the sides, back, top and front of the unit, as well as the distance of the chimney connector to combustible materials. Also, check whether the unit can be placed on a combustible or non combustible floor.

Like all heating appliances, corn burning appliances must only be used to burn the type of fuels recommended by the manufacturer. Heating appliances are tested, listed and/or approved to burn only specific types of fuel (shelled corn, wheat, sorghum, wood pellets, etc).

Corn burning appliances, like all interior heating units, must be vented in accordance with the manufacturer's recommendations. Unlisted single wall metal chimneys shall not be used to vent any interior heating appliance in a one- or two-family residential dwelling, based on NFPA 211.

Corn burning appliances should be vented into one of three types of chimneys/vents:

1. Type "PL" vent
2. Factory-Built Chimney tested and listed to UL 103 or UL 103 HT Standards
3. Clay tile lined masonry chimney

If the type "PL" vent is not stated for use by the appliance manufacturer, the unit must be vented to item number 2 or 3 above.



All heating appliance chimneys should be installed following the 10 foot, 2 foot, 3 foot rule: The chimney or vent pipe must penetrate the roof of the building or enclosure where the heating appliance is located and extend 3 feet above the roof line. The vent or chimney should extend a minimum of 2 feet above the roof ridge or any part of a roof within 10 feet of the chimney or vent pipe. (See page 15 for illustration.)

**Mechanical Work – is** being performed within the building such as a residential garage, machine shed or commercial building.

Then, the installation requirements for the building heating system are as follows:

1. Interior **Forced Air Furnace**:

- Furnace should be installed in a separate room with one hour fire rated construction and the entrance into the room must be from the outside of the building.
- Hot air ducts in the building should terminate not less than 8 feet above the floor.
- Air for combustion should be obtained from the exterior of the building. Combustion air for the interior heating system should NOT be obtained from the building being heated.
- Cold air returns to the furnace should draw air at not less than 8 feet above the floor.

2. Interior **Hot Water Boiler**

- Hot water boiler should be installed in a separate room with one hour fire rated construction and the entrance into the room must be from the outside of the building.
- Air for combustion should be obtained from the exterior of the building. Combustion air for the interior heating system should NOT be obtained from the building being heated.
- Hot water pipes should be located within the concrete floor or they should be connected to radiators or convectors located not less than 8 feet above the floor.

3. Interior **Free Standing Stoves** are **not** acceptable in a repair area where there is the possibility of flammable or combustible liquids being present.

**Mechanical Work** – is **NOT** being performed with a building such as a residential garage, machine shed or commercial building and:

- There is no storage/transfer of flammable and combustible liquids
- **But vehicles ARE stored within such building**

Then, the installation requirements for the building heating system are as follows:

1. Interior **Forced Air Furnace or Hot Water Boiler**:
  - Furnace or Hot Water Boiler should be installed in a separate room with one hour fire rated construction and the entrance into the room the must be from outside of the building.
  - Air for combustion should be obtained from the exterior of the building.
  - Heat ducts into the building may be located 18 inches above the floor level.
  - Cold air returns to the furnace should draw air at not less than 18 inches above the floor.
2. Interior **Free Standing Stoves** are **not** acceptable in a storage area where there is the possibility of flammable or combustible liquids being present.

The interior heating appliance and chimney/vent pipes of the interior unit must be maintained and cleaned. in accordance with the manufacturer's recommendations. GMRC recommends at a MINIMUM that the chimney/vent pipe on any type of corn burning appliance be inspected and cleaned on an annual basis by an outside professional chimney sweep.

Homeowners operating corn burning appliances should have at least one 10 lb ABC Dry Chemical portable fire extinguisher or the equivalent to, located within a visible and easily accessible location within the home or building. Also, smoke detectors should be installed near each sleeping room and at the bottom of each stairway of the home. Consideration should also be given to installing at least one Carbon Monoxide detector in all buildings or structures where a corn burning appliance is present. Check with your local fire marshal for specific codes in your area.

# **Guidelines for Exterior Woodburning and Cornburning Furnaces and Boilers**

Exterior units like all interior heating systems within buildings GMRC insures or reinsures, must be tested, listed and approved by a nationally recognized organization following established recognized safety standards (i.e. UL 391 is the Solid Fuel Burning Standard). Nationally recognized organizations include, UL, CSA International, Warnock Hersey, etc.

The unit must be specifically designed for exterior installations (i.e. installing a heating system that was designed, tested, listed and/or approved for interior installation outside of a building or enclosure is NOT acceptable).

The heating system must be installed in accordance with the manufacturer's recommendations with regards to clearances to combustible buildings or structures (i.e. some manufacturers recommendations can range from 5 feet to 50 feet).

Exterior heating units, like all heating appliances, must be used to burn the type of fuels recommended by the manufacturer. Heating appliances are tested, listed and/or approved to burn only specific types of fuel (i.e. seasoned firewood, shelled corn, etc).

Exterior heating appliances, like all interior heating units, must be vented in accordance with the manufacturer's recommendations. Unlisted single wall steel pipes are not an acceptable method of venting any interior or exterior heating appliance at a one- or two-family residential property, based on NFPA 211.

Wood burning heating units should be vented to:

- A Factory-Built Chimney which has been tested and approved to UL 103 or UL 103HT Standards
- A clay tile lined masonry chimney.

Corn burning appliance should be vented into one of 3 types of chimneys/vents:

- A Type "L" vent
- A Factory-Built Chimney tested and approved to UL 103 or UL 103 HT Standards
- A Clay tile lined masonry chimney.

All heating appliance chimneys should be installed following the 10 foot, 2 foot, 3 foot rule (i.e. The chimney or vent pipe must penetrate the roof of the building or enclosure where the heating appliance is located and extend 3 feet above the roof line. The vent or chimney should extend a minimum of 2 feet above the roof ridge or any part of a roof within 10 feet of the chimney or vent pipe (i.e. if an exterior heating appliance was located less than 10 feet from the exterior of a one story or two story building, the vent or chimney on the exterior unit would be required to extend 2 feet above the roof of the main building within 10 feet of the chimney or vent pipe).

**Mechanical Work – is** being performed within the building such as a residential garage, machine shed or commercial building.

Exterior **Forced Air Furnace**, installation requirements are:

- Hot air ducts into the building should terminate not less than 8 feet above the floor.
- Air for combustion should be obtained from the exterior of the building. Combustion air for the exterior heating system should NOT be obtained from the building being heated.

Exterior **Hot Water Boiler**, installation requirements are:

- The hot water pipes should be located within the concrete floor or they should be connected to radiators or convectors located not less than 8 feet above the floor.

**Mechanical Work – is NOT** being performed with a building such as a residential garage, machine shed or commercial building and:

- There is no storage/transfer of flammable and combustible liquids

Exterior **Forced Air Furnace**, installation requirements

- Heat ducts into the building should terminate not less than 18-inches above the floor.
- Air for combustion should be obtained from the exterior of the building.

Exterior **Hot Water Boiler**, installation requirements are:

- Hot water pipes entering the building should be located not less than 18 inches above the floor.

The exterior heating appliance and chimney/vent pipes of the exterior unit must be maintained and cleaned. in accordance with the manufacturer's recommendations. GMRC recommends at a MINIMUM that the chimney/vent pipe on any type of solid fuel burning appliance be inspected and cleaned on an annual basis by an outside professional chimney sweep.

# Solid-Fuel Burning Appliance Checklist

Name of Manufacturer: \_\_\_\_\_

Is this a Listed Unit (according to Underwriters Laboratory standards)?

• If No, GMRC does not recommend insuring  Yes  No

Unit Listed by: \_\_\_\_\_

## Clearance From Combustible Walls:

If a listed unit, is it installed the proper distance to combustible material as listed on the name plate?  Yes  No

If the above is No, the following are approved clearance reduction systems. ONE of the following should be checked.

Use the distances for **listed** (according to UL standards) units only.

	<u>FROM WALL</u>	<u>FROM CEILING</u>		
3½ inch masonry wall without ventilated air space .....	24"		<input type="checkbox"/> Yes	<input type="checkbox"/> No
1/2 inch noncombustible insulation board over 1 inch glass fiber or mineral wool batts without ventilated air space .....	18"	24"	<input type="checkbox"/> Yes	<input type="checkbox"/> No
24 gauge sheet metal over 1 inch glass fiber or mineral wool batts reinforced with wire or equivalent on rear face with 1 inch ventilated air space .....	12"	18"	<input type="checkbox"/> Yes	<input type="checkbox"/> No
3½ inch masonry wall with 1 inch ventilated air space .....	12"		<input type="checkbox"/> Yes	<input type="checkbox"/> No
24 gauge sheet metal with 1 inch ventilated air space .....	12"	18"	<input type="checkbox"/> Yes	<input type="checkbox"/> No
1/2 inch noncombustible insulation board with 1 inch ventilated air space...	12"	18"	<input type="checkbox"/> Yes	<input type="checkbox"/> No
24 gauge sheet metal with 1 inch ventilated air space over 24 gauge sheet metal with ventilated air space....	12"	18"	<input type="checkbox"/> Yes	<input type="checkbox"/> No
1 inch glass fiber or mineral wool batts sandwiched between two sheets of 24 gauge sheet metal with 1 inch ventilated air space .....	12"	18"	<input type="checkbox"/> Yes	<input type="checkbox"/> No

If none of the above are Yes, what are the clearances:

From wall? \_\_\_\_\_ From ceiling? \_\_\_\_\_

Is miscellaneous combustible material the proper distance from the appliance? .....  Yes  No

---

---

**Clearance From Combustible Floors:**

Does floor protection extend 18 inches outward on all sides of the appliance? .....  Yes  No

Three types of floor protection are required depending on the distance of the unit's fire box to combustible floor. ONE of the following should be checked.

Greater than 6 inches between unit and floor, is there at least a 2 inch thickness of brick, concrete or stone covered by 24 gauge steel? .....  Yes  No

2 to 6 inches between unit and floor, is there 4 inches of hollow masonry laid for air circulation covered by 24 gauge steel? .....  Yes  No

Less than 2 inches between unit and floor, is there no combustible material under the unit? .....  Yes  No

If none of the above are Yes, what are the clearances? \_\_\_\_\_

---

---

**Connecting (Stove) Pipe:**

Is all of the stove pipe visible from the woodburner to the chimney?.....  Yes  No

Is the stove pipe as short and straight as possible, and have a horizontal run not longer than 75% of the height of the chimney above the connector? .....  Yes  No

Is the stove pipe 24 gauge steel or heavier metal? .....  Yes  No

Is there a minimum slope of 1/4 inch per foot from the appliance up to the chimney? .....  Yes  No

Is the stove pipe as large as the outlet size of the appliance?.....  Yes  No

Is the stove pipe void of a **heat reclaimer**? .....  Yes  No

Is a damper installed in the stove pipe? .....  Yes  No

---

---

**Connecting (Stove) Pipe Clearance From Combustibles:**

Clearance to unprotected combustible material ..... 18 inches  Yes  No

If the above is No, the following are approved clearance reduction systems. ONE of the following should be checked.

	<u>FROM WALL</u>	<u>FROM CEILING</u>		
24 gauge sheet metal spaced out one inch .....	6"	9"	<input type="checkbox"/> Yes	<input type="checkbox"/> No
3½ inch thick masonry wall .....	12"		<input type="checkbox"/> Yes	<input type="checkbox"/> No
24 gauge sheet metal over one inch glass fiber or mineral wool batts reinforced with wire, or equivalent, spaced out one inch	6"	9"	<input type="checkbox"/> Yes	<input type="checkbox"/> No

If none of the above are Yes, what are the clearances? \_\_\_\_\_  
\_\_\_\_\_

---

---

**Connecting (Stove) Pipe Clearance Passing Through Combustible Walls:**

Check ONE of the following if stove pipe passes through combustible wall.

Sections of listed factory-built chimney installed the proper distance as marked on the chimney section .....  Yes  No

All combustible material cut away from connector to maintain 18 inch clearance, noncombustible material used to close up such openings .....  Yes  No

**Chimney:**

- Type of approved Chimney:  Masonry with approved liner  
 Listed metal triple wall all fuel  
 Listed metal insulated all fuel  
 Listed prefabricated all fuel (non-metal)

Name brand of chimney: \_\_\_\_\_

If none of the above, explain: \_\_\_\_\_  
\_\_\_\_\_

Does the chimney have a 2 inch clearance from all combustibles, such as joists, rafters, wall panels? .....  Yes  No



Does a **separate** chimney serve only the woodburning appliance?.....  Yes  No

Is the chimney void of any obstructions or bends?.....  Yes  No

If No, explain: \_\_\_\_\_

Is the flue (chimney) size as large as the connecting (stove) pipe? .....  Yes  No

Is there an air-tight connection around the stove pipe into the flue (chimney) inlet?.....  Yes  No

When was creosote last cleaned from chimney? \_\_\_\_\_

*Creosote should be cleaned monthly, when 1/4" accumulation is noted or as often as necessary.*

Is the chimney at least 3 feet above the roof and 2 feet above any roof surface within 10 feet?.....  Yes  No

Is the chimney located outside or inside the dwelling? .....  Outside  Inside

General condition of chimney: .....  Unacceptable  Good  Excellent

---

Are ashes stored in a metal container with lid, sitting on a noncombustible surface?.....  Yes  No

Is at least one 10-pound ABC dry chemical fire extinguisher available? .....  Yes  No

Are smoke detectors installed in all levels of the dwelling? .....  Yes  No

Are carbon monoxide detectors installed in the dwelling? .....  Yes  No

Is the solid fuel burning device located in the garage? (if it is, it should be removed).....  Yes  No

**Any ONE of the questions checked No is a deficiency and can cause serious fire problems.**

Consult NFPA No. 211 on the correct installation procedure for hazards noted on this form.





Distributed as a public service by

**GRINNELL MUTUAL**  
**REINSURANCE**  **SINCE 1909**

[grinnellmutual.com](http://grinnellmutual.com)

*In Cooperation with:*

**NAMIC<sup>®</sup>**

National Association of  
Mutual Insurance Companies  
3601 Vincennes Road  
P. O. Box 68700  
Indianapolis, IN 46268  
(317) 875-5250  
[www.namic.org](http://www.namic.org)